

TOX®-Pneumohydraulic Unit Type KT

- The TOX®-Powerpackage with remote working cylinder
- Pneumohydraulic Press Forces from 2 – 1700 kN
TOX®-Hydrosplit Coupling solenoid operated



TOX®-Hydraulic Cylinder HZL and HZO max. 250 bar oil pressure

All new hydraulic cylinders are supplied in the suitable execution. For the choice of the cylinder the type of medium for the return stroke decides whether the type HZL with air driven return stroke or the oil driven type HZO is more suitable. The hydraulic cylinder HZL

features absolute air/oil separation and allows the return stroke with air pressure (min. 3 bar). Only the HZO features special seals for oil/oil operation and can be used with hydraulic units with max. 250 bar oil pressure for the return stroke. Please observe the

max. allowable retract forces as shown on the table below, dependent on type. Up to 6 hydraulic cylinders HZ can be normally connected to one air-to-oil intensifier ES (more are possible on request).

Type HZ 29/48/74

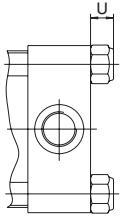

Type HZ 02/05/07/11/19

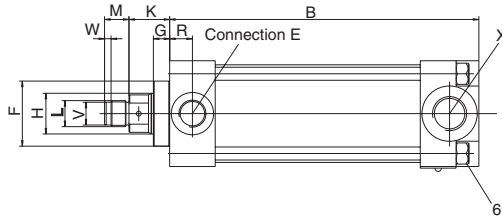

Type HZ 02/05/07/11/19/29

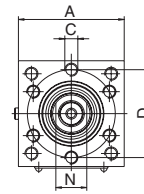

Type HZ 48

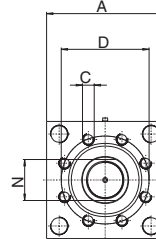

Type HZ 74

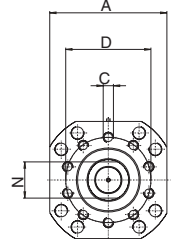

Example HZL

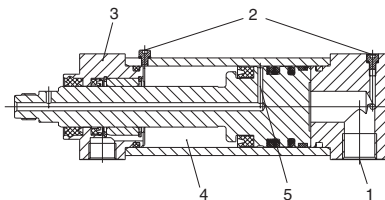

- 1 High pressure connection
- 2 Bleed screw
- 3 Special guiding system
- 4 Return stroke (observe max. allowed return force "F_{RHmax}" for oil/oil operation)
- 5 Absolute air/oil separation (HZL)
- 6 Tie rod

HZ with total stroke adjustment version 151 and ISO execution on request

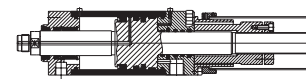

1 Calculation for system selection
 max. oil pressure **250** : max. press force kN **48** x required press force for application (kN) **40** = required oil pressure for application (bar) **208** **STOP**

2 Calculation of the volumetric displacement power stroke
 required volume displacement per 1 mm power stroke **V 2,0** x required power stroke for application (mm) **12** + factor 1 depending on total stroke **F₁ 4,3** + factor 2 per 100 mm hose length **F₂ (0,5x10) + 1,4** (ZHK18)

3 Calculation of volumetric displacement fast approach stroke
 required volume displacement per 1 mm total stroke always take total stroke of cylinder **V 2,0** x total stroke of cylinder in mm **100**

Order no.	Type Version Stroke	Max. press force at 250 bar oil pressure	Fast approach force at 6 bar	Retractive force at 6 bar	Retractive force (F _{RHmax}) max with oil/oil operation	V cm ³	F ₁	F ₂ per 100 mm hose length	Dimensions in mm															
									A	B	C	D	E	F _{R7}	G	H	K	L	M	N	W	Vg6	R	U
HZx 2.101.50	23	17	10	9	0,9	0,9	0,2	55	160	6xM6x12	42	G1/8	32	9,5	16	27	M12x1,5	12	14	4	10	10	-	G1/4
HZx 2.101.100	23	17	10	9	0,9	1,7	0,2	55	210	6xM6x12	42	G1/8	32	9,5	16	27	M12x1,5	12	14	4	10	10	-	G1/4
HZx 2.101.150	23	17	10	9	0,9	2,4	0,2	55	260	6xM6x12	42	G1/8	32	9,5	16	27	M12x1,5	12	14	4	10	10	-	G1/4
HZx 2.101.200	23	17	10	9	0,9	3,2	0,2	55	310	6xM6x12	42	G1/8	32	9,5	16	27	M12x1,5	12	14	4	10	10	-	G1/4
HZx 5.101.50	48	40	25	20	2,0	2,2	0,5	65	190	6xM8x12	54	G3/8	40	10	25	25	M16x1,5	15	19	4	14	14	-	G1/2
HZx 5.101.100	48	40	25	20	2,0	4,3	0,5	65	240	6xM8x12	54	G3/8	40	10	25	25	M16x1,5	15	19	4	14	14	-	G1/2
HZx 5.101.150	48	40	25	20	2,0	6,5	0,5	65	290	6xM8x12	54	G3/8	40	10	25	25	M16x1,5	15	19	4	14	14	-	G1/2
HZx 5.101.200	48	40	25	20	2,0	8,6	0,5	65	340	6xM8x12	54	G3/8	40	10	25	25	M16x1,5	15	19	4	14	14	-	G1/2
HZx 7.101.50	76	70	35	25	3,1	3,4	0,6	80	210	6xM8x16	65	G3/8	52	10	35	25	M24x1,5	19	30	6	22	18	-	G3/4
HZx 7.101.100	76	70	35	25	3,1	6,9	0,6	80	260	6xM8x16	65	G3/8	52	10	35	25	M24x1,5	19	30	6	22	18	-	G3/4
HZx 7.101.150	76	70	35	25	3,1	10,3	0,6	80	310	6xM8x16	65	G3/8	52	10	35	25	M24x1,5	19	30	6	22	18	-	G3/4
HZx 7.101.200	76	70	35	25	3,1	13,7	0,6	80	360	6xM8x16	65	G3/8	52	10	35	25	M24x1,5	19	30	6	22	18	-	G3/4
HZx 11.101.50	108	115	70	25	4,4	4,9	0,6	90	210	6xM10x16	68	G3/8	52	10	35	25	M24x1,5	19	30	6	22	18	-	G3/4
HZx 11.101.100	108	115	70	25	4,4	9,7	0,6	90	260	6xM10x16	68	G3/8	52	10	35	25	M24x1,5	19	30	6	22	18	-	G3/4
HZx 11.101.150	108	115	70	25	4,4	14,6	0,6	90	310	6xM10x16	68	G3/8	52	10	35	25	M24x1,5	19	30	6	22	18	-	G3/4
HZx 11.101.200	108	115	70	25	4,4	19,4	0,6	90	360	6xM10x16	68	G3/8	52	10	35	25	M24x1,5	19	30	6	22	18	-	G3/4
HZx 19.101.50	192	210	125	40	7,9	8,6	0,7	125	235	6xM16x25	100	G1/2	75	10	50	28	M30x2	25	41	7	26	24	-	G1
HZx 19.101.100	192	210	125	40	7,9	17,3	0,7	125	285	6xM16x25	100	G1/2	75	10	50	28	M30x2	25	41	7	26	24	-	G1
HZx 19.101.150	192	210	125	40	7,9	25,9	0,7	125	335	6xM16x25	100	G1/2	75	10	50	28	M30x2	25	41	7	26	24	-	G1
HZx 19.101.200	192	210	125	40	7,9	34,5	0,7	125	385	6xM16x25	100	G1/2	75	10	50	28	M30x2	25	41	7	26	24	-	G1
HZx 29.101.50	300	355	235	110	12,3	13,5	0,7	160	298	8xM20x30	115	G3/4	80	15	55	47	M39x2	35	50	-	-	27	22	G1
HZx 29.101.100	300	355	235	110	12,3	27,0	0,7	160	348	8xM20x30	115	G3/4	80	15	55	47	M39x2	35	50	-	-	27	22	G1
HZx 29.101.150	300	355	235	110	12,3	40,6	0,7	160	398	8xM20x30	115	G3/4	80	15	55	47	M39x2	35	50	-	-	27	22	G1
HZx 29.101.200	300	355	235	110	12,3	54,1	0,7	160	448	8xM20x30	115	G3/4	80	15	55	47	M39x2	35	50	-	-	27	22	G1
HZx 48.101.50	492	630	390	245	20,1	22	0,7	200	300	8xM20x30	150	G3/4	125	25	80	60	M64x2	60	70	-	-	27	30	G1
HZx 48.101.100	492	630	390	245	20,1	44	0,7	200	350	8xM20x30	150	G3/4	125	25	80	60	M64x2	60	70	-	-	27	30	G1
HZx 48.101.150	492	630	390	245	20,1	66	0,7	200	400	8xM20x30	150	G3/4	125	25	80	60	M64x2	60	70	-	-	27	30	G1
HZx 48.101.200	492	630	390	245	20,1	88	0,7	200	450	8xM20x30	150	G3/4	125	25	80	60	M64x2	60	70	-	-	27	30	G1
HZx 74.101.50	770	1050	655	245	31,4	35	0,7	275	366	10xM24x40	200	G3/4	150	25	100	65	M64x2	60	85	-	-	38	30	G1
HZx 74.101.100	770	1050	655	245	31,4	70	0,7	275	416	10xM24x40	200	G3/4	150	25	100	65	M64x2	60	85	-	-	38	30	G1
HZx 74.101.150	770	1050	655	245	31,4	105	0,7	275	466	10xM24x40	200	G3/4	150	25	100	65	M64x2	60	85	-	-	38	30	G1
HZx 74.101.200	770	1050	655	245	31,4	140	0,7	275	516	10xM24x40	200	G3/4	150	25	100	65	M64x2	60	85	-	-	38	30	G1

Adaptor with internal thread to fit the piston rod end

Dimensions in mm
 See data sheet 10.00 TOX®-Powerpackage for mounting specifications, pressure tolerances ± 5 %

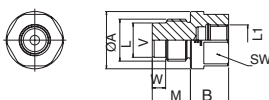

Type	Fits to	ØA	B	L1	L	M	W	Vg6	SW
HZZ 012.016.020.000	HZx2	22	20	M12x1,5	M16x1,5	15	4	14	19
HZZ 016.022.020.000	HZx5	30	20	M16x1,5	M22x2	20	7	18	27
HZZ 024.030.030.000	HZx7/HZx11	45	30	M24x1,5	M30x2	25	7	26	41
HZZ 030.039.040.000	HZx19	56	40	M30x2	M39x2	35	-	-	50

TOX®-Intensifier ES with fast approach function

For CAD downloads, please visit us at www.tox-en.com

The power intensifier with absolute air/oil separation and integrated bypass for reliable operation. Can be mounted in any orientation.

Includes all valves for automatic changeover from fast approach to power stroke, and the air spring regulator. Uses simple pneumatic controls like any double acting pneumatic cylinder.

Closed oil system. Hose connection with TOX®-Hydrosplit coupling. Color coded pneumatic plug-in system. **Simply perfect.**

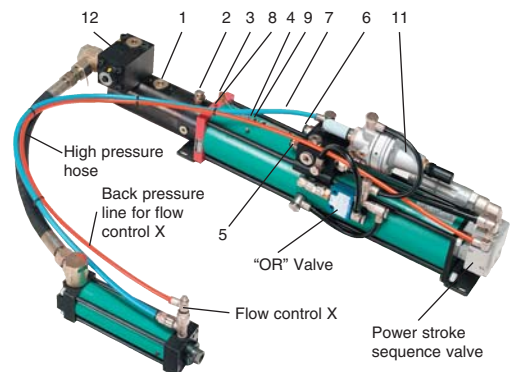
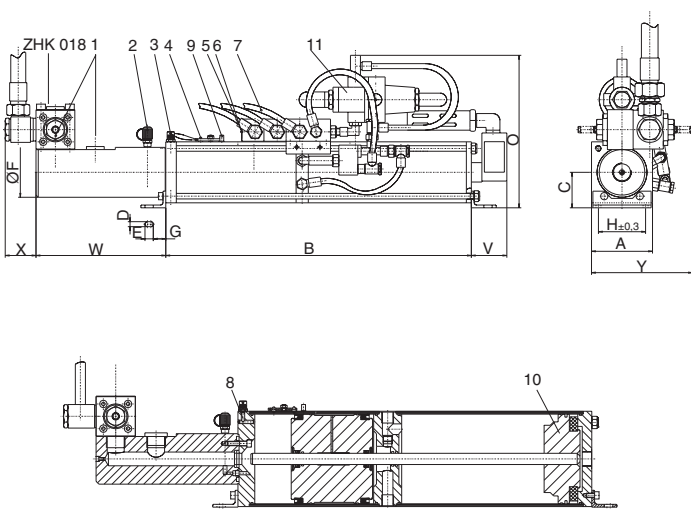

- 1 High pressure port
- 2 High pressure measuring and control connection
- 3 Oil filling nipple
- 4 Bleed plate
- 5 Air connection fast approach stroke
- 6 Air connection return stroke
- 7 Return stroke air line
- 8 Oil level indicator
- 9 Patented anti-overfill device
- 10 Intensifier piston
- 11 Air spring valve
- 12 Hydrosplit coupling

4

Calculated oil-pressure ① 208 : 54 = **3,85** Required air pressure for application (bar)

= required volumetric displacement for power stroke (cm³) **34,7** X Number of cylinders

= required volumetric displacement for fast approach stroke (cm³) **200** X Number of cylinders

2 Required total volumetric displacement power stroke for application (cm³) = **69,4**

2 Required total volumetric displacement fast approach stroke for application (cm³) = **400**

Order no.	A	B	C	D	E	F	G	H	O	V	W	X	Y	Connection Fast approach	Connection Return stroke	Connection High pressure	Volumetric displacement for fast app. stroke cm³	Volumetric displacement for power stroke cm³	Oil pressure at 1 bar air pressure bar	Max. air pressure bar	Max. oil pressure bar
ES 100.100.022.70	110	551	64	9	15	90	22,5	85	265	110	234	max. 100	240	G1/2	G1/2	G3/4	360	22	57*	6	345**
ES 160.100.085.64	170	731	86	9	15	95	22,5	85	330	130	303	max. 100	300	G3/4	G3/4	G3/4	1300	85	54*	6	328**
ES 250.100.216.80	267	886	134,5	9	15	130	22,5	85	427	150	395	max. 100	340	G1	G1	G3/4	4600	216	66*	6	400**
ES 300.100.381.62	324	867	167	14	20	130	92	100	484	150	379	max. 100	400	G1	G1	G3/4	6100	381	52*	6	316**
ES 350.100.500.76	368	1075	189	14	20	145	92	100	528	150	450	max. 100	420	G1	G1	G3/4	10700	500	64*	6	388**
ES 350.100.830.76	368	1457	189	14	20	145	92	100	528	150	709	max. 100	420	G1	G1	G3/4	15000	830	64*	6	388**
ES 100.100.039.39	110	551	64	9	15	90	22,5	85	265	110	234	max. 100	240	G1/2	G1/2	G3/4	350	39	35*	10	355**
ES 160.100.134.41	170	731	86	9	15	90	22,5	85	330	130	303	max. 100	300	G3/4	G3/4	G3/4	1300	134	36*	10	365**
ES 250.100.395.43	267	886	134,5	9	15	130	22,5	85	427	150	395	max. 100	340	G1	G1	G3/4	4600	395	38*	10	385**
ES 300.100.665.36	324	867	167	14	20	130	92	100	484	150	379	max. 100	400	G1	G1	G3/4	6000	665	33*	10	330**
ES 350.100.844.45	368	1075	189	14	20	145	92	100	528	150	450	max. 100	420	G1	G1	G3/4	10600	844	41*	10	410**

Dimensions in mm *Caution: theoretical pressure and power values shown may differ from values on actual pressure table. ** Pressure tolerance ± 5%

"Your way to find the right KT system" 4 = values corresponding to your application

- 1** The actual required press force, e. g. 40 kN, leads to the selection of a cylinder with max. 48 kN press force. The calculation results in 208 bar required oil pressure.
- 2** The volume required for your case can be found by multiplying the required power stroke, e.g. 12 mm, times the type specific volume factor V (e.g. 2). The factor F₁ + F₂ is added to the previous result (whereby F₂ depends on the hose length, e.g. 1000 mm). Then, add a factor of 1.4 for each ZHK 018 Hydrosplit coupling. Finally, multiply by the number of cylinders, e.g. 2, resulting in a required oil volume of 69.4 cm³. This leads to selection of an ES with 85 cm³.
- 3** The stroke required for your application leads you to selection of a cylinder with a total stroke of 100 mm, which multiplied times the volumetric factor V and the number of cylinders, e.g. 2, results in a total volumetric displacement of 400 cm³. Check this value against that of the selected intensifier, e.g. 1300 cm³, which in this example is enough.
- 4** The oil pressure calculated in step ①, in this case 208 bar, is divided by the oil pressure produced by the intensifier at 1 bar air pressure, e.g. 54 bar. The result is the required air pressure for the application. In order to obtain high stroke frequencies, the air pressure should always be about 20% higher. Caution: the maximum pressure/press force of the cylinder must not be exceeded.

When using different cylinders and different hose lengths, the calculation of the volume must be done individualy for each cylinder. Then add the combined results.

TOX®-Working Cylinder AT max. 400 bar oil pressure

The pneumo-hydraulic cylinder with double-bearing working piston. Fast approach and return stroke by

applying pressure to the working part. This results in high fast approach and return stroke forces.

Absolute separation of air and oil. Up to 6 working units AT can be connected to an air-to-oil intensifier ES.

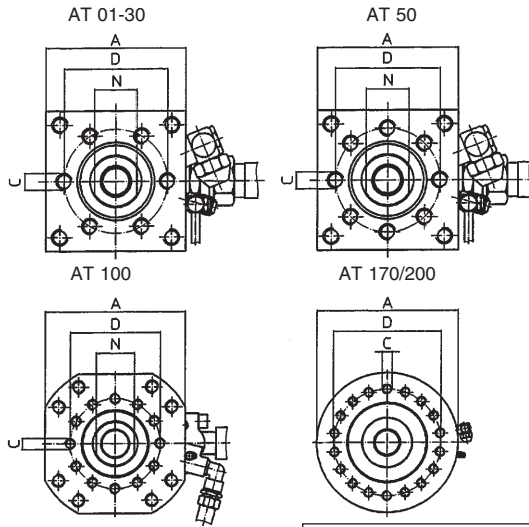
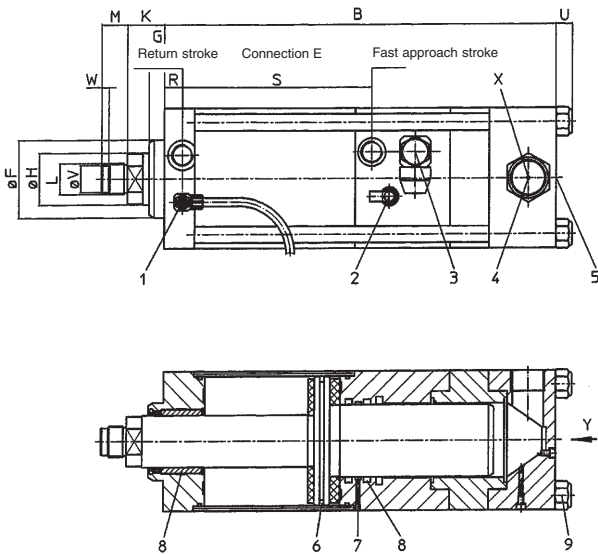

- 1 Control throttle for start of power stroke
- 2 Oil high pressure measuring connection
- 3 Power stroke air connection to ES
- 4 High pressure port from ES
- 5 Bleed screw
- 6 Special seals
- 7 Absolute air/oil separation
- 8 Double supported working piston
- 9 Tie rod

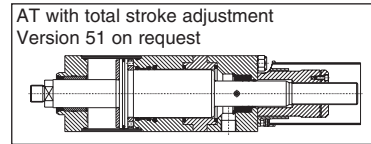

Order no.	type stroke	Max. press force at 400 bar oil pressure	Fast approach force *** at 6 bar	Retractive force at 6 bar	V		F ₁		F ₂ per 100 mm hose length		Dimensions															
					cm ³	cm ³	daN	daN	A	B	C	D	E	F ₁₇	G	H	K	L	M	N	R	S	U	X	V ₉₅	W
					1 Calculation for system selection max. oil pressure bar 400 : max. press force kN 81 x required press force for application (kN) 50 = required oil pressure for application (bar) 246 STOP																					
					2 Calculation of the volumetric displacement power stroke Required volumetric displacement per 1 mm power stroke V 1,96 x required power stroke for the application (mm) 12 + factor 1 depending on total stroke F₁ 6,5 + factor 2 per 100 mm hose length F₂ (0,9x10) + 1,5 (ZHK18) 11 (ZHK42)																					
					3 Calculation of volumetric displacement fast approach stroke Required volumetric displacement per 1 mm total stroke, always take total stroke of cylinder V 1,96 x total stroke of cylinder mm 100																					
AT 1. 50.	13	69	72	0,31	0,6	0,4	50	229	6xM6x11	40	G1/8	30	10	16	24	M12x1,5	12	14	11,5	106,5	6	G1/2	-	-		
AT 1. 100.	13	69	72	0,31	1,0	0,4	50	329	6xM6x11	40	G1/8	30	10	16	24	M12x1,5	12	14	11,5	156,5	6	G1/2	-	-		
AT 1. 200.	13	69	72	0,31	1,8	0,4	50	529	6xM6x11	40	G1/8	30	10	16	24	M12x1,5	12	14	11,5	256,5	6	G1/2	-	-		
AT 1. 250.	13	69	72	0,31	2,3	0,4	50	629	6xM6x11	40	G1/8	30	10	16	24	M12x1,5	12	14	11,5	306,5	6	G1/2	-	-		
AT 2. 50.	21	140	150	0,49	0,8	0,7	70	242	6xM8x12	54	G1/4	40	10	20	26	M16x1,5	15	17	13	116	8	G1/2	-	-		
AT 2. 100.	21	140	150	0,49	1,4	0,7	70	342	6xM8x12	54	G1/4	40	10	20	26	M16x1,5	15	17	13	166	8	G1/2	-	-		
AT 2. 200.	21	140	150	0,49	2,6	0,7	70	542	6xM8x12	54	G1/4	40	10	20	26	M16x1,5	15	17	13	266	8	G1/2	-	-		
AT 2. 300.	21	140	150	0,49	3,9	0,7	70	742	6xM8x12	54	G1/4	40	10	20	26	M16x1,5	15	17	13	366	8	G1/2	-	-		
AT 4. 50.	42	180	195	1,02	2,3	0,7	85	258	6xM8x15	64	G3/8	50	10	30	28,5	M22x2	20	24	14	125	10	G1/2	18	7		
AT 4. 100.	42	180	195	1,02	3,1	0,7	85	355	6xM8x15	64	G3/8	50	10	30	28,5	M22x2	20	24	14	175	10	G1/2	18	7		
AT 4. 200.	42	180	195	1,02	5,6	0,7	85	555	6xM8x15	64	G3/8	50	10	30	28,5	M22x2	20	24	14	275	10	G1/2	18	7		
AT 4. 300.	42	180	195	1,02	8,1	0,7	85	755	6xM8x15	64	G3/8	50	10	30	28,5	M22x2	20	24	14	375	10	G1/2	18	7		
AT 4. 400.	42	180	195	1,02	10,6	0,7	85	955	6xM8x15	64	G3/8	50	10	30	28,5	M22x2	20	24	14	475	10	G1/2	18	7		
AT 8. 50.	81	320	330	1,96	4,1	0,9	110	288	6xM10x16	88	G1/2	70	10	45	35	M30x2	25	36	17	133	12	G3/4	26	7		
AT 8. 100.	81	320	330	1,96	6,5	0,9	110	371	6xM10x16	88	G1/2	70	10	45	35	M30x2	25	36	17	183	12	G3/4	26	7		
AT 8. 200.	81	320	330	1,96	11,2	0,9	110	571	6xM10x16	88	G1/2	70	10	45	35	M30x2	25	36	17	283	12	G3/4	26	7		
AT 8. 300.	81	320	330	1,96	15,9	0,9	110	771	6xM10x16	88	G1/2	70	10	45	35	M30x2	25	36	17	383	12	G3/4	26	7		
AT 8. 400.	81	320	330	1,96	20,6	0,9	110	971	6xM10x16	88	G1/2	70	10	45	35	M30x2	25	36	17	483	12	G3/4	26	7		
AT 15. 50.	158	450	550	3,85	8,4	1,1	135	293	6xM16x25	100	G1/2	75	15	50	36	M30x2	25	41	17,5	134,5	16	G1	26	7		
AT 15. 100.	158	450	550	3,85	12,9	1,1	135	381	6xM16x25	100	G1/2	75	15	50	36	M30x2	25	41	17,5	185	16	G1	26	7		
AT 15. 200.	158	450	550	3,85	22,0	1,1	135	581	6xM16x25	100	G1/2	75	15	50	36	M30x2	25	41	17,5	285	16	G1	26	7		
AT 15. 300.	158	450	550	3,85	31,0	1,1	135	781	6xM16x25	100	G1/2	75	15	50	36	M30x2	25	41	17,5	385	16	G1	26	7		
AT 15. 400.	158	450	550	3,85	40,0	1,1	135	981	6xM16x25	100	G1/2	75	15	50	36	M30x2	25	41	17,5	485	16	G1	26	7		
AT 30. 50.	320	660	930	7,85	17,4	1,1	170	362	6xM20x30	132	G3/4	100	18	56	47	M39x2	35	50	20	186	22	G1	-	-		
AT 30. 100.	320	660	930	7,85	26,5	1,1	170	425	6xM20x30	132	G3/4	100	18	56	47	M39x2	35	50	20	236	22	G1	-	-		
AT 30. 200.	320	660	930	7,85	44,7	1,1	170	625	6xM20x30	132	G3/4	100	18	56	47	M39x2	35	50	20	336	22	G1	-	-		
AT 30. 300.	320	660	930	7,85	62,8	1,1	170	825	6xM20x30	132	G3/4	100	18	56	47	M39x2	35	50	20	436	22	G1	-	-		
AT 30. 400.	320	660	930	7,85	81,0	1,1	170	1025	6xM20x30	132	G3/4	100	18	56	47	M39x2	35	50	20	536	22	G1	-	-		
AT 50. 50.	498	720	1200	12,27	18,2	1,1	200	390	8xM20x30	150	G3/4	115	25	63	52	M42x2	40	55	23	193	30	G1	-	-		
AT 50. 100.	498	720	1200	12,27	34,8	1,1	200	440	8xM20x30	150	G3/4	115	25	63	52	M42x2	40	55	23	243	30	G1	-	-		
AT 50. 200.	498	720	1200	12,27	62,7	1,1	200	640	8xM20x30	150	G3/4	115	25	63	52	M42x2	40	55	23	343	30	G1	-	-		
AT 50. 300.	498	720	1200	12,27	90,5	1,1	200	840	8xM20x30	150	G3/4	115	25	63	52	M42x2	40	55	23	443	30	G1	-	-		
AT 100. 100.	1030	1260	2200	25,45	71,5	3,1	310	534	12xM24x40	200	G1	150	25	100	60	M64x2	60	85	35	253	30	SAE	-	-		
AT 100. 200.	1030	1260	2200	25,45	128,7	3,1	310	734	12xM24x40	200	G1	150	25	100	60	M64x2	60	85	35	353	30	flange	-	-		
AT 100. 300.	1030	1260	2200	25,45	185,9	3,1	310	934	12xM24x40	200	G1	150	25	100	60	M64x2	60	85	35	453	30	2"	-	-		
AT 170. 200.	1670	1570	2530	41,55	178,8	3,1	420	844	18xM30x55	320	G1"	240	35	150	70	M80x2	80	4xØ16	99	353	30	SAE 2"	-	-		

AT 200 on request ***Approach stroke assist available on request Dimensions in mm See data sheet 10.00 TOX®-Powerpackage for mounting specifications, pressure tolerances ± 5 %

TOX®-Intensifier ES with fast approach function

The power intensifier with absolute air/oil separation and integrated bypass for reliable operation. Can be mounted in any orientation.

Includes all valves for automatic changeover from fast approach to power stroke, and the air spring regulator. Uses simple pneumatic controls like any double acting pneumatic cylinder.

Closed oil system. Hose connection with TOX®-Hydrosplit coupling. Color coded pneumatic plug-in system. **Simply perfect.**

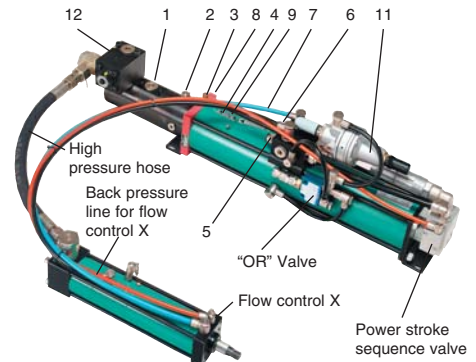
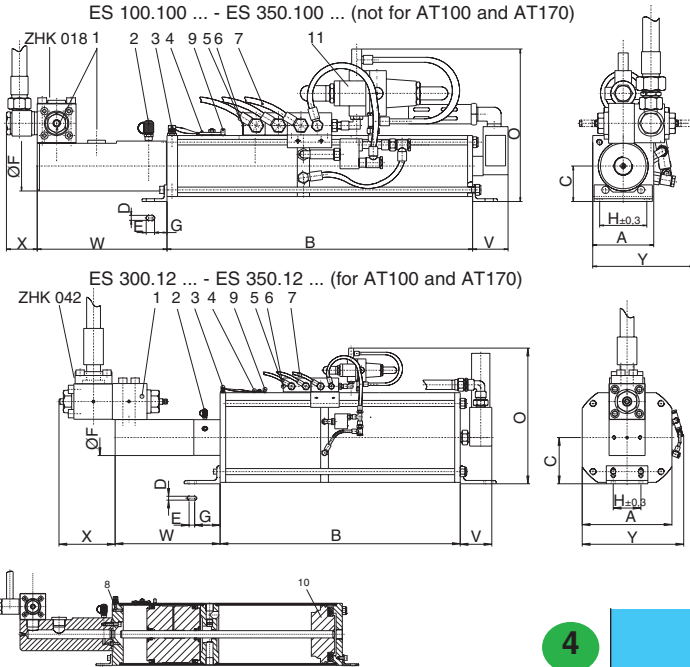

- 1 High pressure port
- 2 High pressure measuring and control connection
- 3 Oil filling nipple
- 4 Bleed plate
- 5 Air connection fast approach stroke
- 6 Air connection return stroke
- 7 Return stroke air line
- 8 Oil level indicator
- 9 Patented anti-overflow device
- 10 Intensifier piston
- 11 Air spring valve
- 12 Hydrosplit coupling

Calculated oil pressure ① $246 : 54 = 4,55$ Required air pressure for application (bar)

= required volumetric displacement for power stroke (cm³) **40,52** X Number of cylinders **2** = **81,04**

= required volumetric displacement for fast approach stroke (cm³) **196** X Number of cylinders **2** = **392**

Order no.	A	B	C	D	E	F	G	H	O	V	W	X	Y	Connection Fast approach	Connection Return stroke	Connection High pressure	Volumetric displacement for fast app. stroke cm ³	Volumetric displacement for power stroke cm ³	Oil pressure at 1 bar air pressure bar	Max. air pressure bar	Max. oil pressure bar
ES 100.100.022.70	110	551	64	9	15	90	22,5	85	265	110	234	max. 100	240	G1/2	G1/2	G3/4	360	22	57*	6	345**
ES 160.100.085.64	170	731	86	9	15	95	22,5	85	330	130	303	max. 100	300	G3/4	G3/4	G3/4	1300	85	54*	6	328**
ES 250.100.216.80	267	886	134,5	9	15	130	22,5	85	427	150	395	max. 100	340	G1	G1	G3/4	4600	216	66*	6	400**
ES 300.100.381.62	324	867	167	14	20	130	92	100	484	150	379	max. 100	400	G1	G1	G3/4	6100	381	52*	6	316**
ES 350.100.500.76	368	1075	189	14	20	145	92	100	528	150	450	max. 100	420	G1	G1	G3/4	10700	500	64*	6	388**
ES 350.100.830.76	368	1457	189	14	20	145	92	100	528	150	709	max. 100	420	G1	G1	G3/4	15000	830	64*	6	388**
ES 100.100.039.39	110	551	64	9	15	90	22,5	85	265	110	234	max. 100	240	G1/2	G1/2	G3/4	350	39	35*	10	355**
ES 160.100.134.41	170	731	86	9	15	90	22,5	85	330	130	303	max. 100	300	G3/4	G3/4	G3/4	1300	134	36*	10	365**
ES 250.100.395.43	267	886	134,5	9	15	130	22,5	85	427	150	395	max. 100	340	G1	G1	G3/4	4600	395	38*	10	385**
ES 300.100.665.36	324	867	167	14	20	130	92	100	484	150	379	max. 100	400	G1	G1	G3/4	6000	665	33*	10	330**
ES 350.100.844.45	368	1075	189	14	20	145	92	100	528	150	450	max. 100	420	G1	G1	G3/4	10600	844	41*	10	410**
ES 350. 12.381.62	324	867	167	14	20	130	92	100	484	150	379	max. 205	400	G1	G1	SAE2"	6100	381	52*	6	316**
ES 350. 12.500.76	368	1075	189	14	20	145	92	100	528	150	450	max. 205	420	G1	G1	SAE2"	10700	50	64*	6	388**
ES 350. 12.830.76	368	1457	189	14	20	145	92	100	528	150	709	max. 205	420	G1	G1	SAE2"	15000	830	64*	6	388**
ES 350. 12.844.45	368	1075	189	14	20	145	92	100	528	150	450	max. 205	420	G1	G1	SAE2"	10600	844	41*	10	410**

Dimensions in mm *Caution: theoretical pressure and power values shown may differ from values on actual pressure table. ** Pressure tolerance ± 5%

"Your way to find the right KT system" 2 = values corresponding to your application

- 1** The actual required press force, e. g. 50 kN, leads to the selection of a cylinder with max. 81 kN press force. The calculation results in 246 bar required oil pressure.
- 2** The volume required for your case can be found by multiplying the required power stroke, e.g. 12 mm, times the type specific volume factor V (e.g. 1.96). The factor F₁ + F₂ is added to the previous result (whereby F₂ depends on the hose length, e.g. 1000 mm). Then, add a factor of 1.5 for each ZHK 018 Hydrosplit coupling. Finally, multiply by the number of cylinders, e.g. 2, resulting in a required oil volume of 81.04 cm³. This leads to selection of an ES with 85 cm³.
- 3** The stroke required for your application leads you to selection of a cylinder with a total stroke of 100 mm, which multiplied times the volumetric factor V and the number of cylinders, e.g. 2, results in a total volumetric displacement of 392 cm³. Check this value against that of the selected intensifier, e.g. 1300 cm³, which in this example is enough.
- 4** The oil pressure calculated in step ①, in this case 246 bar, is divided by the oil pressure produced by the intensifier at 1 bar air pressure, e.g. 54 bar. The result is the required air pressure for the application. In order to obtain high stroke frequencies, the air pressure should always be about 20% higher. Caution: the maximum pressure/press force of the cylinder must not be exceeded.

When using different cylinders and different hose lengths, the calculation of the volume must be done individually for each cylinder. Then add the combined results.

Hydraulic hoses

The connection between the drive cylinders and the pneumo-hydraulic intensifier

Variant no.	Cylinder HZ/AT side	Intensifier ES side	Connection
ZS 01			2 x straight connection
ZS 02			1 x 90° elbow on ES 1 x straight connection on HZ/AT
ZS 03			1 x straight connection on ES 1 x 90° elbow on HZ/AT

Ordering example for hoses: ZS 01 - 1000

— hose length
— variant no.

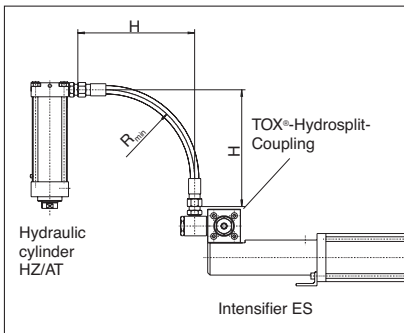

Allocation of the hydraulic hoses to the drive cylinders

Drive	Standard hose lengths [mm]	Hose dimensions [mm]				
		A	B	C	H _{min}	R _{min}
AT1	500/1000/2000/3000	88	75	84	220	150
AT2/AT4	500/1000/2000/3000	94	85	92	275	200
AT8	500/1000/2000/3000	101	90	74	320	240
AT15/AT30/AT50	500/1000/2000/3000	118	125	137	375	280
AT100	1000/2000/3000	200	200	176	1120	920
AT170	1000/2000/3000	200	200	176	1120	920
HZ2	500/1000/2000/3000	88	75	84	220	150
HZ5	500/1000/2000/3000	94	85	92	275	200
HZ7/HZ11	500/1000/2000/3000	101	90	74	320	240
HZ19/HZ29/HZ48/HZ74	500/1000/2000/3000	118	125	137	375	280

Other connection variants on request R_{min}: smallest allowable bending radius

Example for the right and wrong installation of hoses

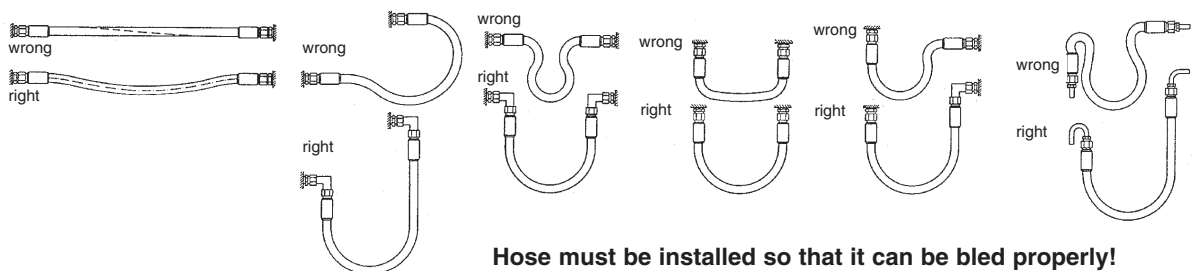

Hose must be installed so that it can be bled properly!

Mounting variants for TOX®-Hydrosplit coupling with 1 – 6 hoses. Swivel fitting allows each hose to be independently oriented.

Standard mounting sequence of the TOX®-Hydrosplit Coupling ZHK18

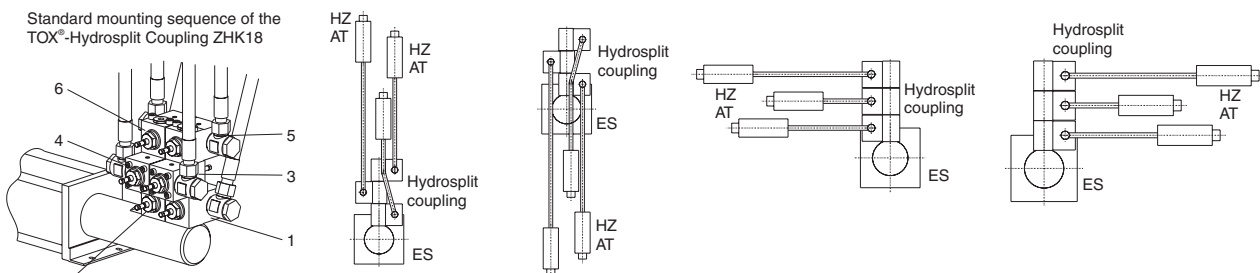

Mounting style 1

Mounting style 2

Mounting style 3

Mounting style 4

TOX®-Hydrosplit Coupling type ZHK

Optimised for flow rate and volume for up to 6 cylinders

In order to ship the components filled with oil and to facilitate installation, we have developed the TOX®-Hydrosplit coupling. This coupling allows for connection of the components without any introduction of air to the system and without any leakage.

TOX®-Hydrosplit coupling, manually switchable, type ZHK 018.000

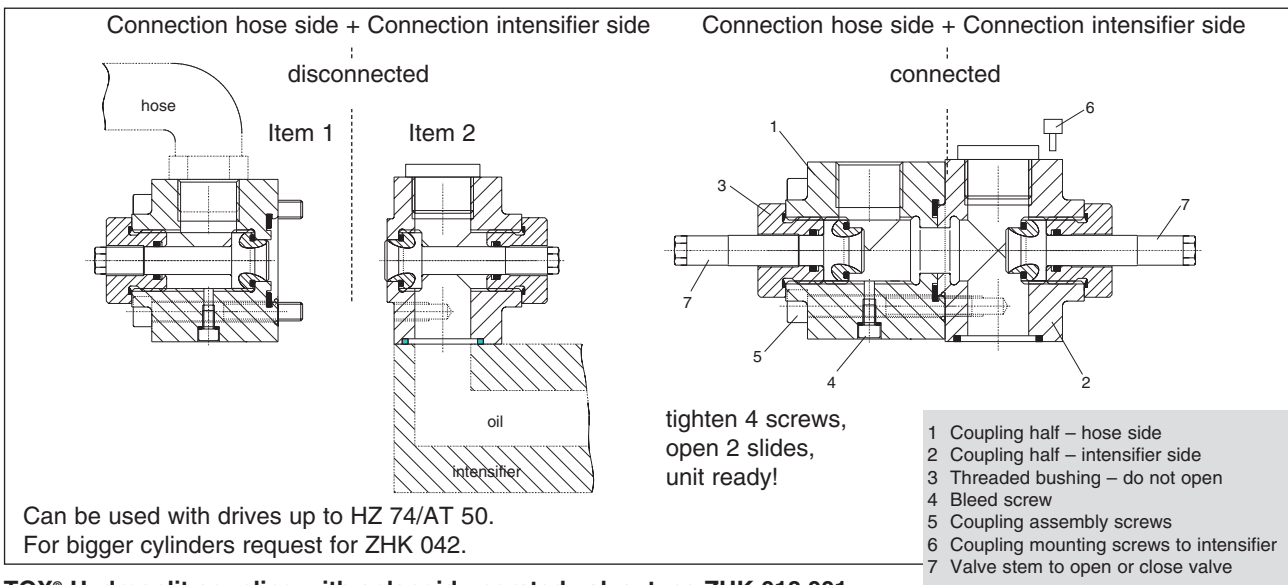

TOX®-Hydrosplit coupling with solenoid operated valve, type ZHK 018.001

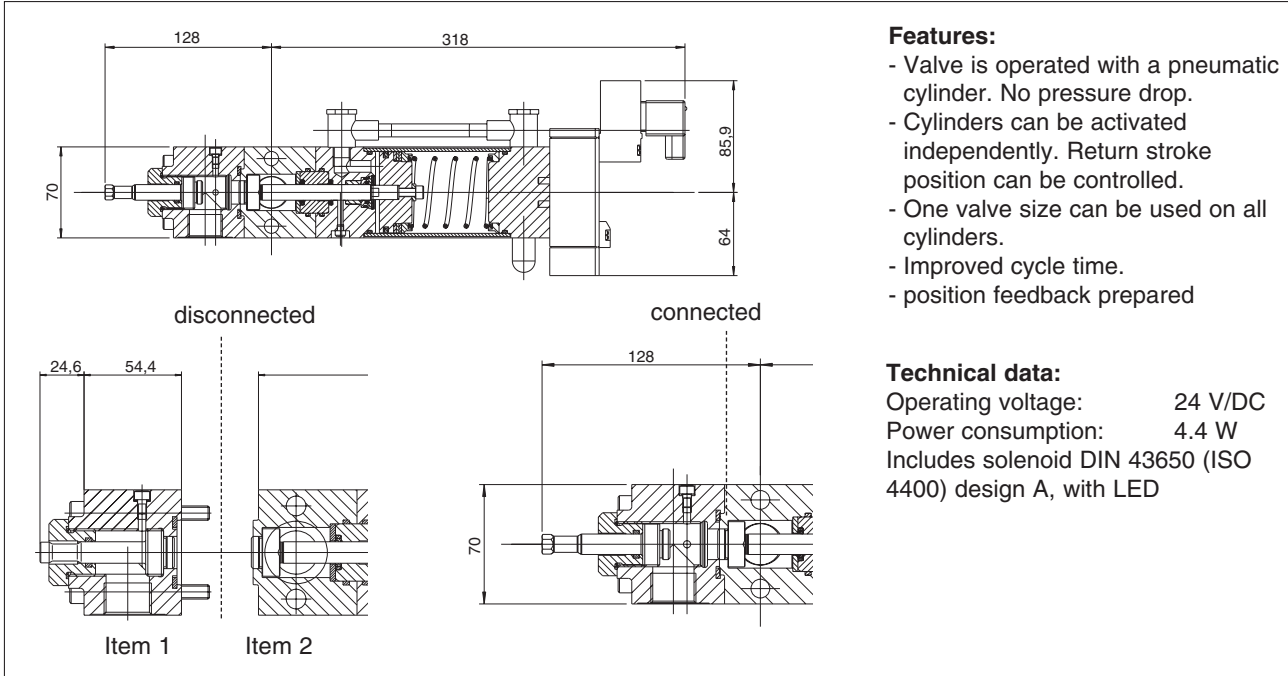

Order data:

1. Order No. type of the working section AT or hydraulic cylinder HZ (**HZL** for air/oil or **HZO** for oil/oil).
2. Intensifier ES order no. type
3. Hydraulic hose ZS variant no., hose length
4. Type Hydrosplit coupling
5. Mounting style of the Hydrosplit coupling

Example:

- | | |
|----------------------|-------------|
| 1. HZL 5.101.100 | quantity: 2 |
| (Air/oil operation) | |
| 2. ES 160.100.085.64 | quantity: 1 |
| 3. ZS 01.1000 | quantity: 2 |
| 4. ZHK 18.000 | |
| 5. Mounting style 1 | |

You will receive:

2 x HZL incl. hose and Hydrosplit coupling part 1.
+ 1 x ES incl. Hydrosplit coupling, manual, with 2x part 2.
Completely filled with oil and **delivered in detached** condition. Ready for connection including colour-coded pneumatic plug-in-system.
Operating instruction

TOX®-Pneumo-hydraulic unit type KT – the system

Long power strokes, drive of several cylinders, color coded pneumatic plug-in-system. Optimum system separation by TOX®-Hydrosplit coupling.

Energy-saving, total pneumatic operation, integrated oil system, absolute air/oil separation, simple construction. Driven as any normal double-acting pneumatic cylinder. Reduced noise level.

The total stroke is divided into three sections:

- air-operated fast approach
 - pneumatic-hydraulic power stroke
 - air-operated return stroke
- or
- pneumatic-hydraulic power stroke only
 - air-operated return stroke

The **changeover** from fast approach to power stroke is fitted to the system as a standard feature and works automatically according to the dynamic pressure principle. The speed of the changeover from fast approach to power stroke can be regulated via throttle "X".

Connection:

The intensifier ES is connected via a hydraulic hose and TOX® hydraulic coupling with working cylinder AT, or the TOX®-Hydraulic cylinder HZ. The unit is driven by a 4/2 or 5/2-way valve.

Items supplied:

TOX®-Intensifier **ES** with TOX® working cylinder **AT** or TOX®-Hydraulic cylinder **HZ**. Drive cylinder with hoses and TOX® Hydrosplit coupling and intensifier **ES** are separately delivered. Simple assembly by **colour-guided** pneumatic plug-in-system of all connection lines. Completely filled with oil. Ready for connection.

For accessories, see data sheet 10.00 TOX®-Powerpackage

