



TOX®-Marking Systems

- TOX®-Marking-Tongs, -Presses, -Powerpackage
- Manual and automatic stamping tools



TOX®-Marking Systems

Modular – also for marking

Drive
available also with the TOX®-PowerKurver KK

Frame

Indexing slide

Marking tool

- Marking
- Coining
- Dimpling

- Extruding
- Countersinking

of

- Steel
- Non-ferrous metals

TOX®-PowerKurver Type: KK 20 / KK 90

The quick approach stroke, the force buildup during the power stroke and the optimum part loading accessibility are some of the key features of the TOX®-PowerKurver KK 20 with a press force capacity up to 20 kN or KK 90 with up to 90 kN. Please contact us for technical data.

Example:
KK with automatically advancing marking tool

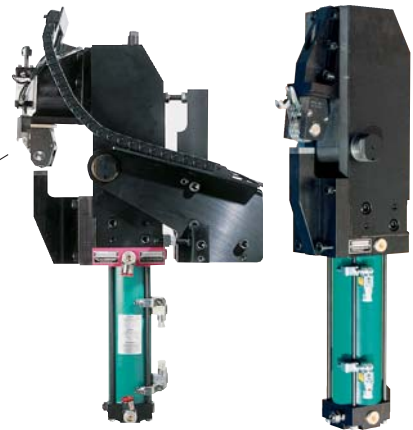

TOX®-Powerpackage type RP for embossing operation With anti-torsion device and spring chuck

Die spigot for stamping tool and type-holder

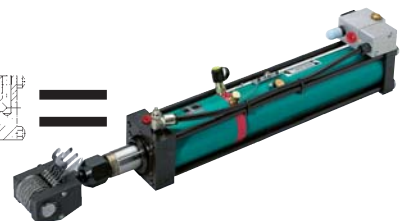
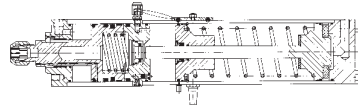
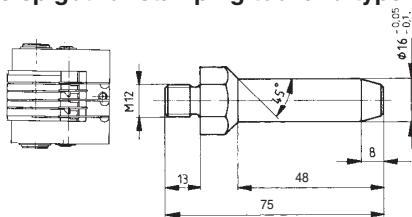

As basic equipment for manual working places and production lines can be used as stamping unit.

- Action:**
1. Fast approach
 2. Automatically initiated power stroke at any point of the fast approach
 3. Return stroke

Refer to data sheet 10.00 TOX®-Powerpackage

Marking Tools Manual Type: PP



Manually adjustable numbering head

- safe, quick setting for frequent number changes
- available in many character sizes
- available with numbers, letters and logos
- replaceable individual wheels
- characters per DIN 1451 standards
- special types, character size, etc. available on request

Items included with delivery:

- marking head
- mounting shank

Can be used with all TOX® drives KK, RP, S, K.

Custom marking tools/characters available upon request.

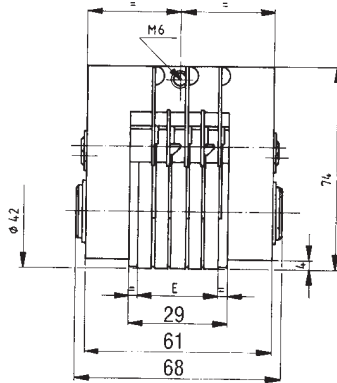
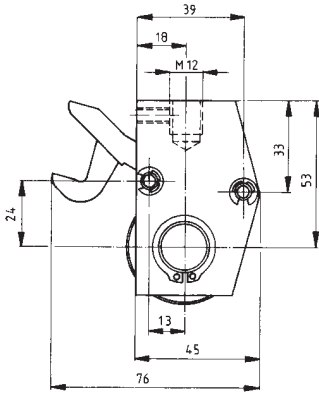

Ordering example:

PP 01.04.04. + Configuration of characters on wheels, e.g. wheel 1 with characters 0 – 9
 Character height
 Number of characters
 Medium type (02 condensed)
 Marking head

Medium standard type 01			
14 positions per wheel		11 p. p. w.	
Number of characters (Number of wheels)			
2	1 2 2,5 3 4 5 6 8	Character height	
3	4,6 5 6 7 9 11 13 17	Marking width E	
4	7,4 8 9,5 11 14 17 20		
5	10,2 11 13 15 19 23		
6	13 14 16,5 19 24		
7	15,8 17 20 23		
8	18,6 20 23,5		
	21,4 23		

Medium condensed type 02			
14 positions per wheel		11 p.p.w.	
Number of characters (Number of wheels)			
2	2 2,5 3 4 5 6 8	Character height	
3	4,6 5 6 7 9 11 13 17	Marking width E	
4	7,4 8 9,5 11 12,5 14 20		
5	10,2 11 13 15 17 19		
6	13 14 16,5 19 21,5		
7	15,8 17 20 23		
8	18,6 20 23,5		
	21,4 23		

All dimensions in mm.

Automatically advancing marking head

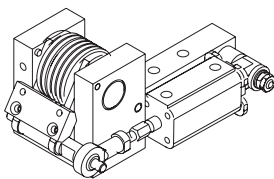

Ordering example:

PP 01.05.A3

Character height 5 mm
 A3: last 3 digits automatic advance
 Number of characters 5
 01 medium type
 02 (medium condensed)

Sequencing example:

1st wheel: fixed, without advance
 2nd wheel: automatic advance, e.g. for character change A, B, C
 3rd. – 5th wheels: automatic advance 1 – 399, e.g. for shift change (to A day counter plus 1)

Dimensions on request.

Automatically advancing numbering marking head

- a mechanical or pneumatic mechanism with a minimum of 25 mm travel will automatically advance one count on each stroke
- available with character sizes up to 8 mm
- characters: numbers, letters, special symbols

Stamps holder type TH

Stamps type PT

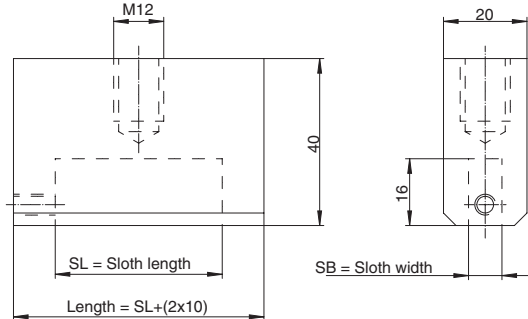

All dimensions in mm
Special on request.

Items included with delivery
- Stamp holder without stamps
- Mounting shank

Ordering example:

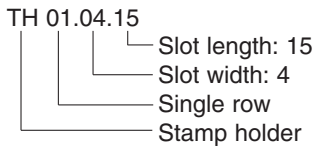

TH (single row)

	SB	SL
TH01	4	15
TH01	4	30
TH01	6	20
TH01	6	40
TH01	8	20
TH01	8	40

Can be used with all drives KK, RP, S, K.

Stamps available individually or in sets

Sizes available

SH = Character height	L = Length	B = Width	Characters available
1,0	1,5	4,0	A - Z
1,5	1,5	4,0	0 - 9
2,0	2,0	4,0	. (Period)
2,5	2,5	6,0	, (Comma)
3,0	3,0	6,0	- (Hyphen)
4,0	4,0	8,0	/ (Slash)
5,0	5,0	8,0	

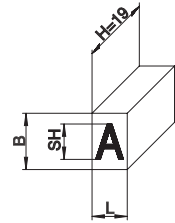

All dimensions in mm

Please observe the corresponding stamp holder for the selected number of characters or stamps.

Characters according to DIN 1451 standards – medium type – beveled – nickel plated.

Ordering example:

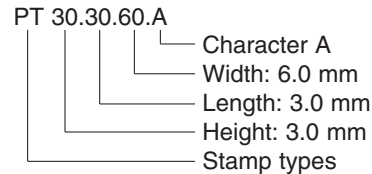

Technical Information

Material characteristics for marking

Tensile strength R_m (N/mm²) for various materials

Material designation	R_m N/mm ²	Material designation	R_m N/mm ²
Steel		Non-ferrous metals	
St 10	280...500	Al 99,5 Al99 soft	70...100
St 12	280...420	Al 99,5 Al99 half-hard	100...150
St 13	280...400	Al Mg 3/5/7 soft	180...380
St 14	280...380	Al Mg 3/5/7 half-hard	220...450
St 37	370...450	Al Cu soft	160...220
St 42	420...500	Al Cu half-hard	380...440
St 50	500...600	Kupfer (Cu)	210...240
St 60	600...720	Zinc (Zn)	120...140
Ck 10	340...400	Nickel (Ni)	400...450
Ck 35	500...600	Lead (Pb)	200...300
Ck 45	600...720	Al Bz 4	300...400
V 2A	620...750	CuZn 10 F 30	350...430

Letter height in mm	Factor A, to be applied mm ²
1	3,4
1,5	5
2	7
3	10
4	14
5	17
6	20
7	23
8	27
10	32
12	40

Base for the calculation of the required stamping force for numbering tools

Formula: $F_p = A \times R_m \times ST$

F_p = marking force

A = factor, see table, mm²

R_m = tensile strength, N/mm²

ST = number of digits

When selecting the appropriate drive unit, allow about 30% reserve force to account for wear of the tools and tolerances in material strengths.

Example:

A marking tool with 6 digits, 5 mm letter height, for a material with tensile strength $R_m = 400$ N/mm², requires the following stamping force:

$$F_p = 17 \text{ mm}^2 \times 400 \text{ N/mm}^2 \times 6 = 40.800 \text{ N}$$

Recommended stamping force to be expected: 40.800 N + 30% reserve = 53.040 N