

Version: 2008-08-06

PRESSE PRESS	KOPF HEAD	GESTELL FRAME	max. Presskraft**		max. Hub max. stroke	A	C	S	K	M	BxT	L	Tisch- bohrung Table bore	Ge- wicht kompl. total weight	Ge- wicht Kopf Head weight	max. Aufbie- gung* max. deflection*	Moy zul. Moment allow. moment	E	F	G	H	I	Klemmverschraubung der Pressenköpfe Klemm- schrauben   Anzugs- moment Tightening press heads screw size   torque		max. Rück- hubkraft** max. return force**
			[kN]	[lbf]																			[Nm]	[Nm]	
PFHL 008.001	PHKL 008.060.001	PGL 008.000	8,5	1911	60	120	30-265	95	674	150x125	339	20	61	26,3	0,1	25	9	94	263	110	1/4	M 12	135	85	
PFHL 013.001	PHKL 013.060.001	PGL 025.000	13,5	2922	60	165	35-375	115	800	200x180	439	20	95	33,7	0,2	25	11	120	330	144	1/4	M 12	135	85	
PFHL 022.001	PHKL 022.060.001	PGL 025.000	22,5	5058	60	165	25-330	115	800	200x180	439	20	120	58,3	0,35	70	11	120	330	144	1/4	M 16	340	73	
PFHL 033.001	PHKL 033.060.001	PGL 033.000	34,5	7756	60	200	35-355	125	820	240x220	534	25	157	73,7	0,45	70	13,5	158	405	164	1/4	M 16	340	73	
PFHL 056.001	PHKL 056.060.001	PGL 056.000	57,5	12926	60	240	55-340	160	860	260x220	614	30	232	91,7	0,7	70	13,5	178	487	190	1/4	M 16	340	73	
PFHW 008.001	PHKL 008.060.001	PGW 008.000	8,5	1911	60	300	205-285	150	745	200x200	624	20	115	26,3	0,2	25	9	145	500	100	1/4	M 12	135	85	
PFHW 013.001	PHKL 013.060.001	PGW 025.000	13,5	2922	60	300	200-280	180	775	240x230	654	20	177	33,7	0,2	25	11	145	520	100	0,25	M 12	135	85	
PFHW 022.001	PHKL 022.060.001	PGW 025.000	22,5	5058	60	300	190-240	180	775	240x230	654	20	200	58,3	0,25	70	11	145	520	100	1/4	M 16	340	73	
PFHW 033.001	PHKL 033.060.001	PGW 033.000	34,5	7756	60	300	210-275	190	805	300x250	674	25	234	73,7	0,35	70	13,5	160	530	100	0,25	M 16	340	73	
PFHW 056.001	PHKL 056.060.001	PGW 056.000	57,5	12926	60	355	185-245	215	825	300x280	789	30	308	91,7	0,45	70	13,5	210	625	130	1/4	M 16	340	73	

Alle Maße in mm.  
 \*Pressenkopf in oberster Position  
 \*\*bei 6 bar Luftdruck (max. Betriebsdruck 6 bar, min. 2,5 bar)  
 C = Ausladung  
 S = Arbeitshöhe verstellbar  
 E = Befestigungsbohrung  
 I = Anschlussquerschnitt [Zoll]  
 Hubeinstellung: 0,04 mm pro Teilstrich  
 Linksmontage des Handhebels ist problemlos möglich  
 Konformitätserklärung kann generell ausgestellt werden

All dimensions in mm  
 \*Press head in uppermost position  
 \*\*at 6 bar air pressure (max. operating pressure 6 bar, min. 2.5 bar)  
 C = throat depth  
 S = Open height, adjustable  
 E = Mounting bore  
 I = Port size (inch)  
 Stroke adjustment: 0.04 mm per increment  
 Left handed version possible  
 Conformity Declaration can be issued

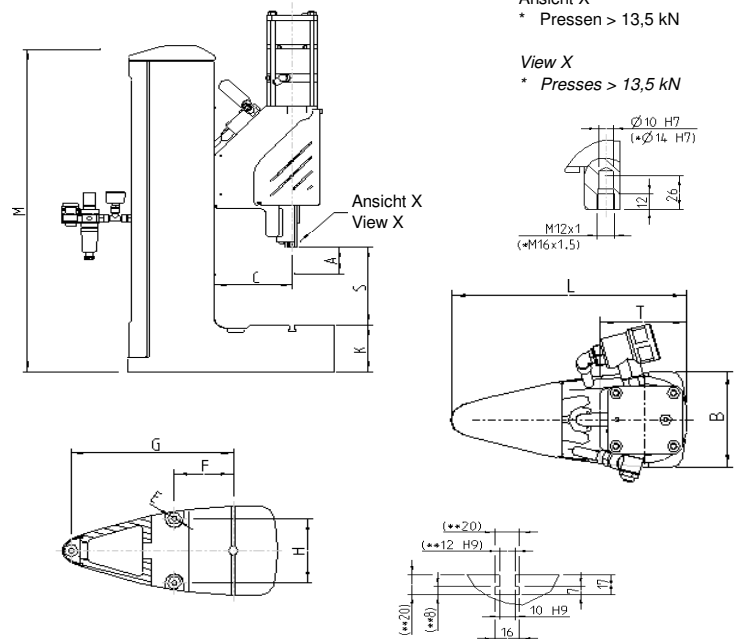
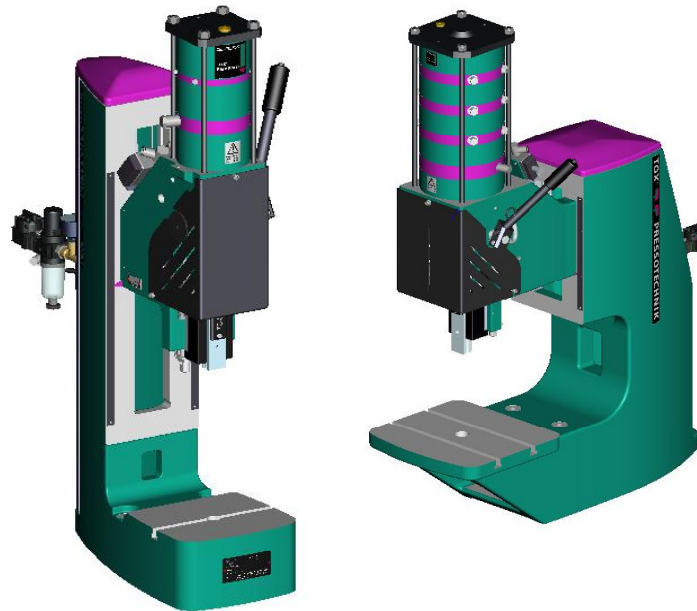

Für Gestell W > 8 kN zwei T-Nuten, Nutabstand 100 mm  
 \*\* Presse 56 kN  
 For frame size W > 8 kN, two T-slots, spaced 100 mm  
 \*\* Press 56 kN